

MATLAB EXPO 2019

AI Techniques in MATLAB for
Signal, Time-Series, and Text Data

First name and surname



AI and Deep Learning for Signals in the News



Deep Learning developed and evolved for image processing and computer vision applications.

It is now increasingly and successfully used on signals and time series

Video: Johns Hopkins University

Tech for a Noisy World: Researchers simulated an extremely noisy environment in the lab (the sound meter shows levels of around 70 decibels). They compared the audio heard through a top-notch commercial stethoscope, in which the breathing sounds are mixed with ambient noise, to that heard through the Johns Hopkins smart stethoscope, which uses active acoustic filtering to isolate the breathing sounds.

The Use of Deep Learning is Growing Across Industries

Aerospace, Defense and Communications



Communications devices, security

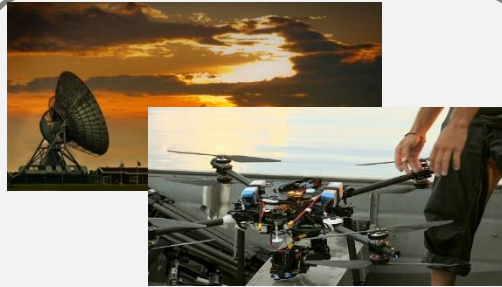

Multi-standard communications receivers, drone recognition

Consumer Electronics and Digital Health



Voice assistants



Digital health

Automotive



Voice control enabled Infotainment



Sensor processing, automated driving

Industrial Automation



Condition monitoring



Predictive maintenance

Application Examples Using MATLAB – Audio and Speech

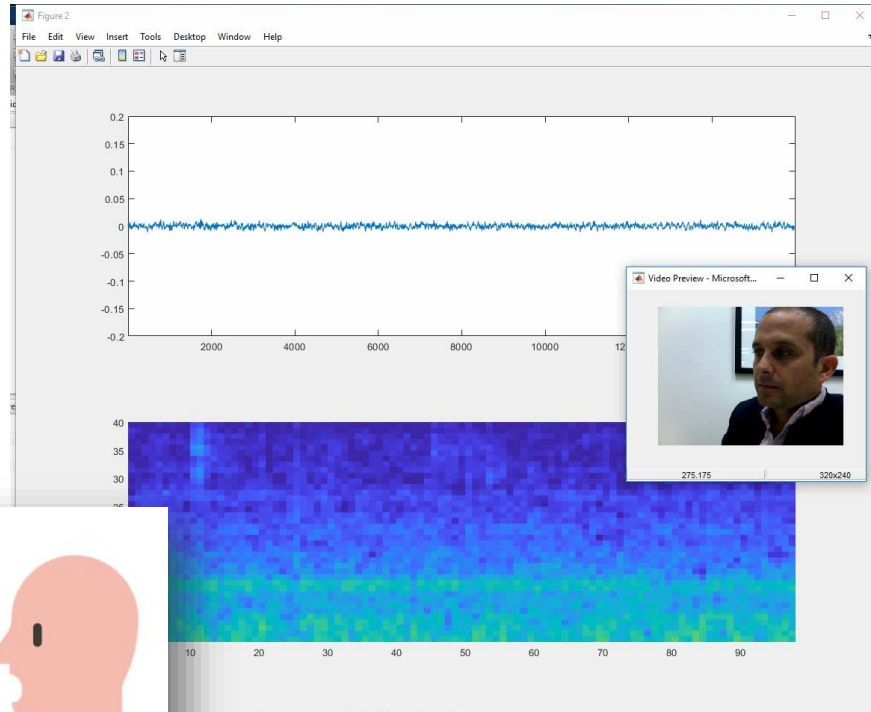

Speech Command Recognition
(a.k.a. "Keyword Spotting")

<https://www.mathworks.com/help/deeplearning/examples/deep-learning-speech-recognition.html>

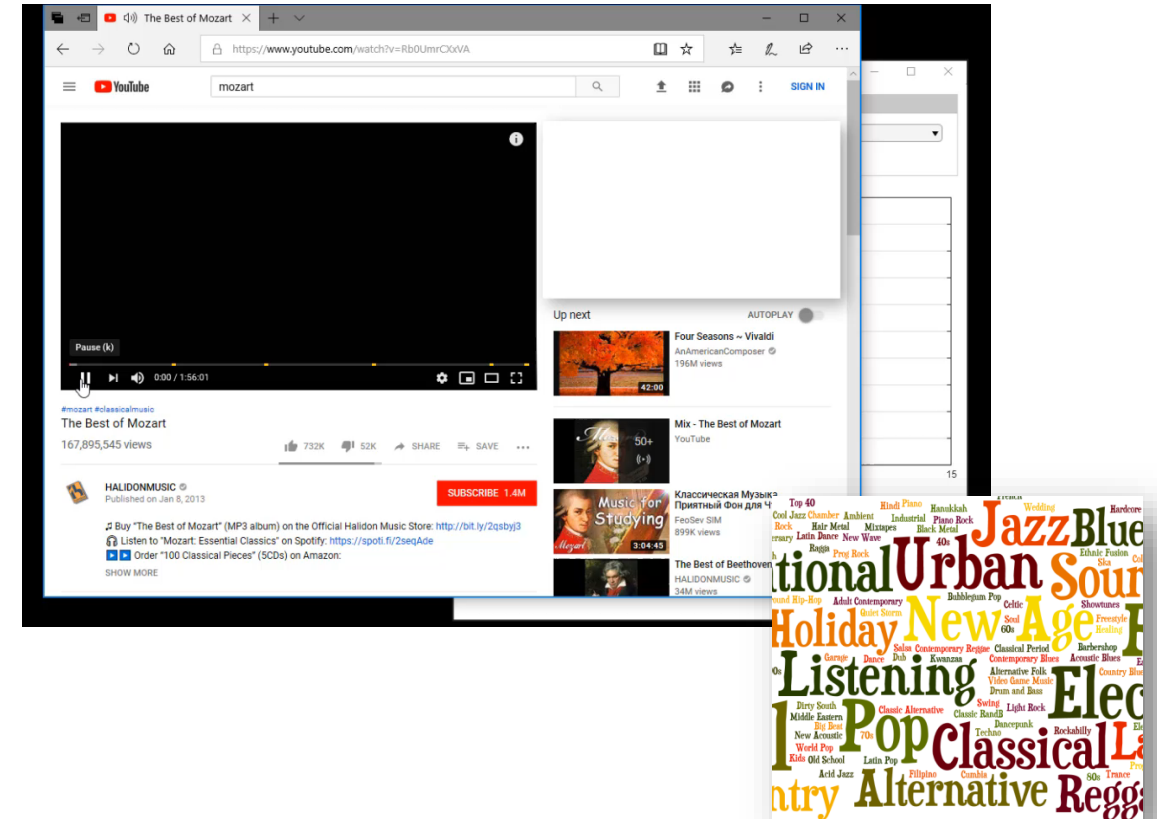

Music Genre Classification

<https://www.mathworks.com/help/audio/examples/music-genre-classification-using-wavelet-time-scattering.html>

Application Examples Using MATLAB – Industrial and physiological sensors

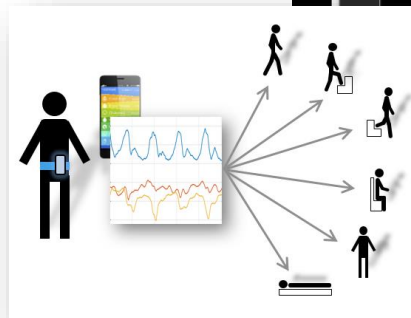
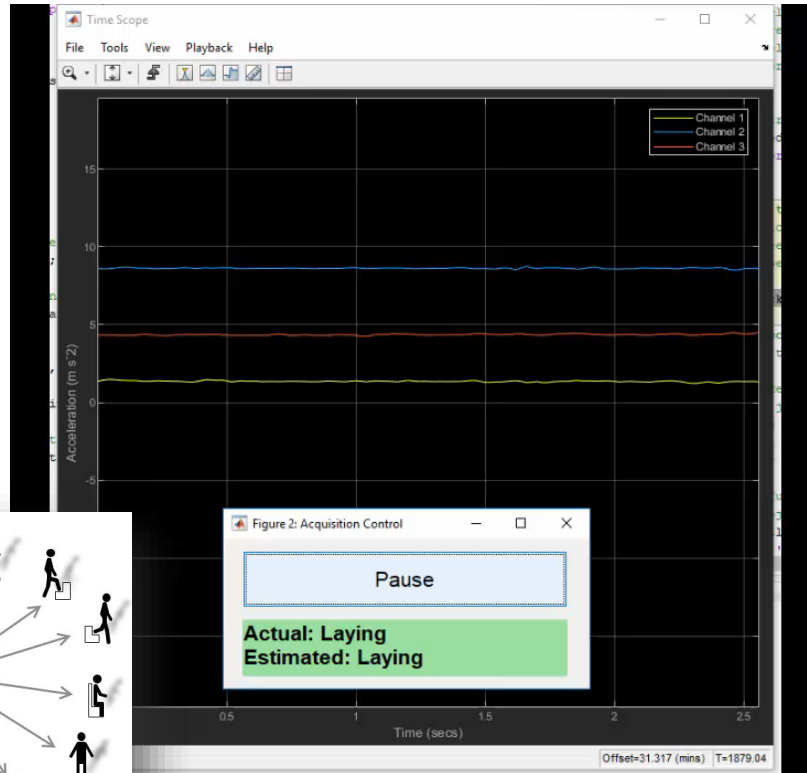

Human Activity Recognition

<https://www.mathworks.com/help/deeplearning/examples/sequence-to-sequence-classification-using-deep-learning.html>

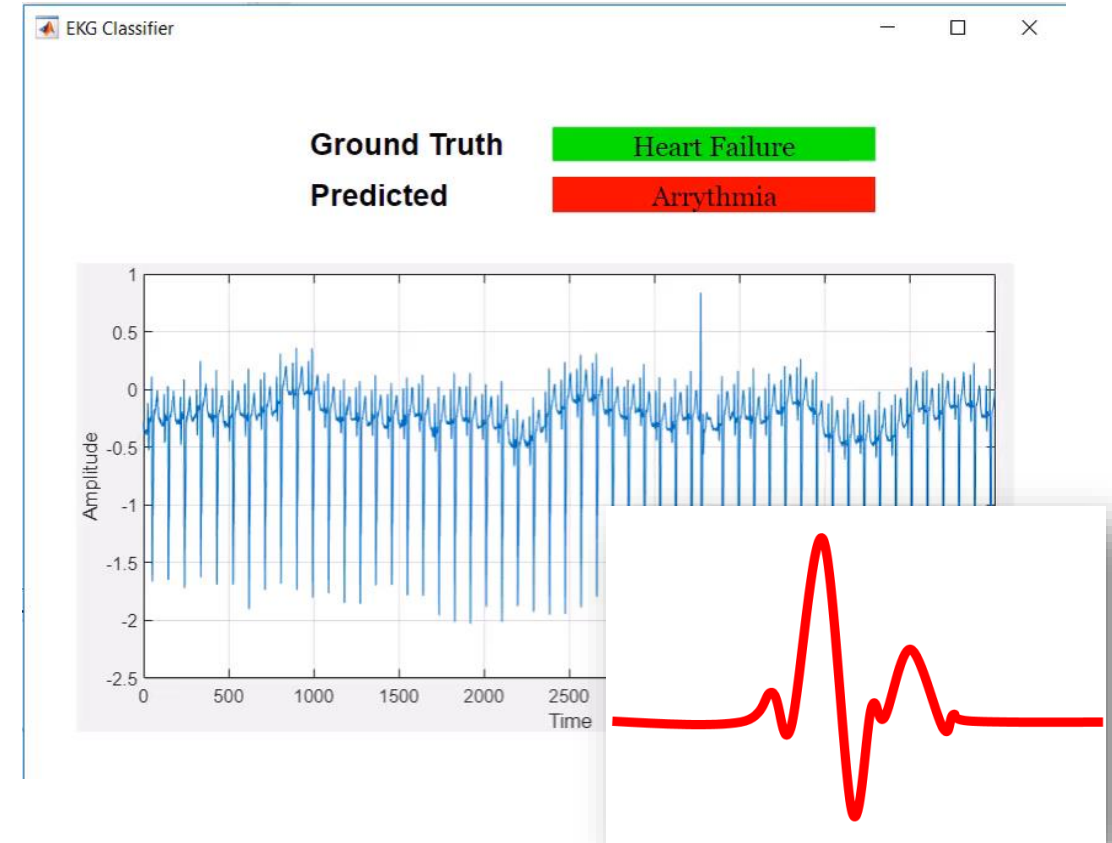

EKG Signal Classification

<https://www.mathworks.com/help/signal/examples/classify-ecg-signals-using-long-short-term-memory-networks.html>

Application Examples Using MATLAB – Radar and Communications

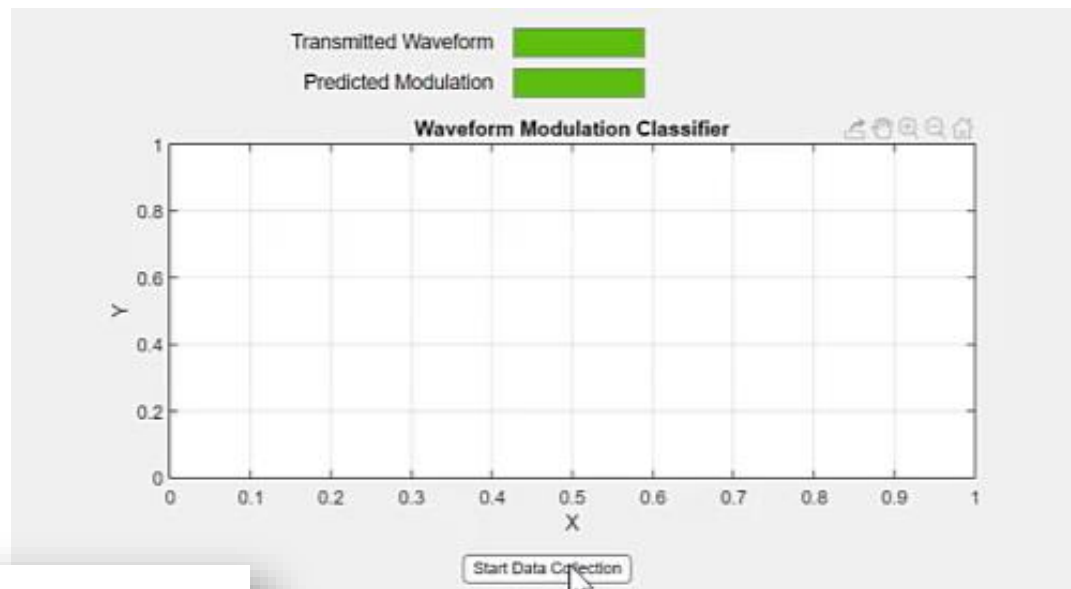

Modulation Classification

<http://www.mathworks.com/help/comm/examples/modulation-classification-with-deep-learning.html>

Confusion Matrix for Test Data

16QAM	89	11								89.0%	11.0%
64QAM	1	99								99.0%	1.0%
8PSK			100							100.0%	
B-FM				100						100.0%	
BPSK					100					100.0%	
CPFSK						100				100.0%	
GFSK							100			100.0%	
PAM4								100		100.0%	
QPSK			4						96	96.0%	4.0%
	16QAM	64QAM	8PSK	B-FM	BPSK	CPFSK	GFSK	PAM4	QPSK		
	Predicted Class										

Agenda

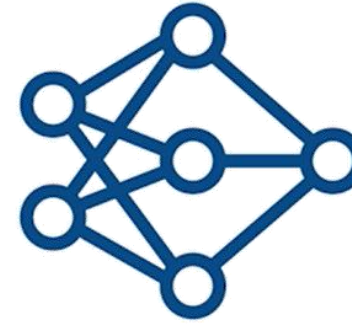

- Deep Learning – Basic ideas
- Deep Learning Model Development for Signals, Time Series, and Text
- Conclusions

What is Deep Learning?

Deep learning is a type of machine learning in which a model learns from examples.

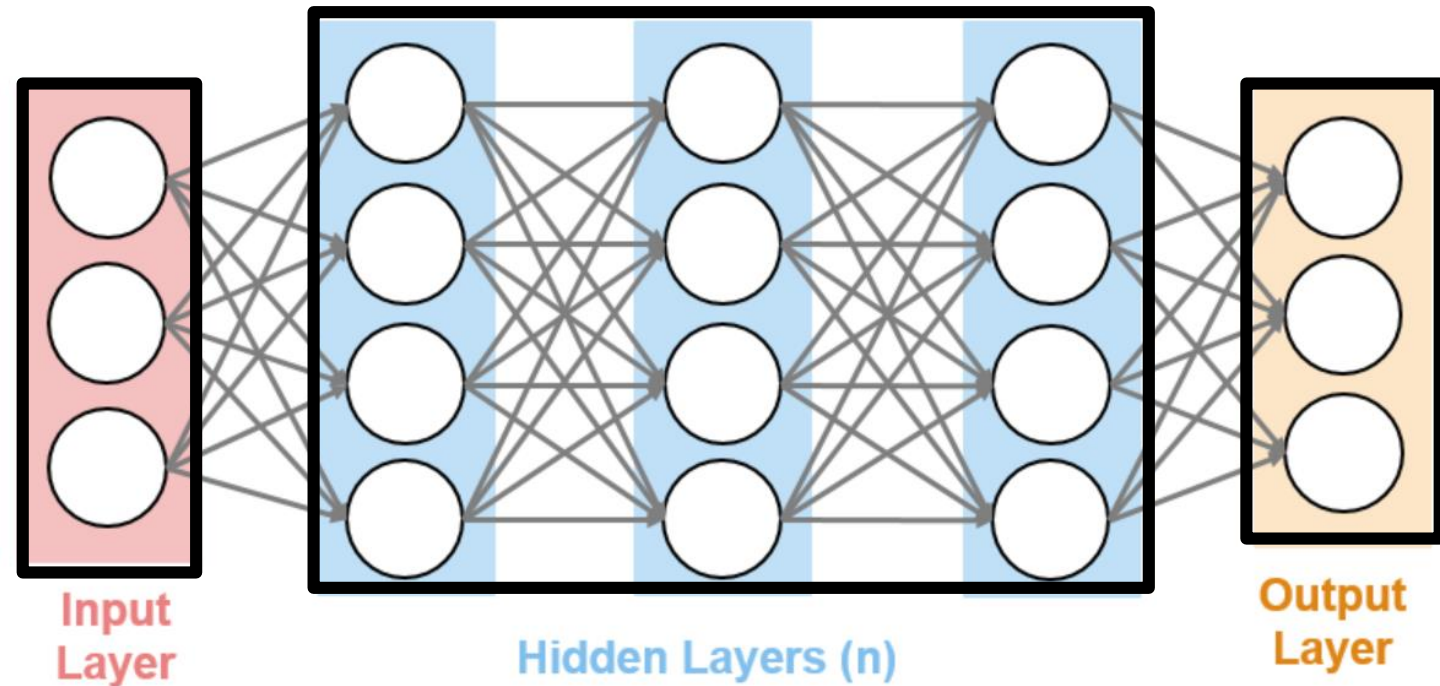

Common Network Architectures - Signal Processing

Convolutional Neural Networks (CNN)

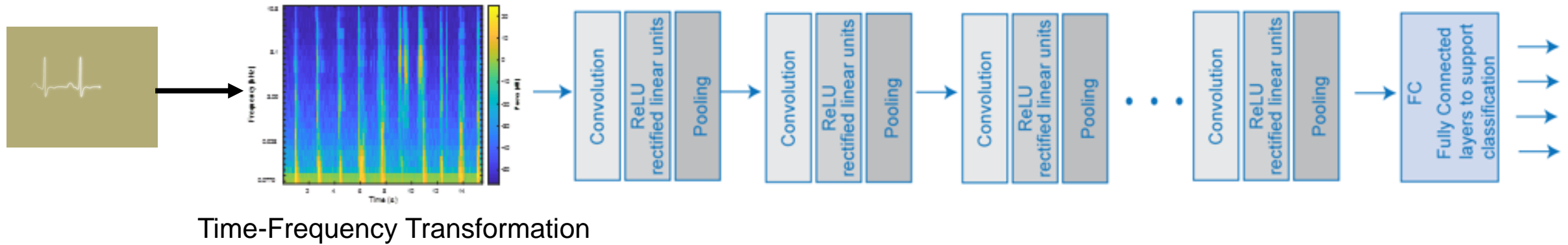

Long Short Term Memory (LSTM) Networks

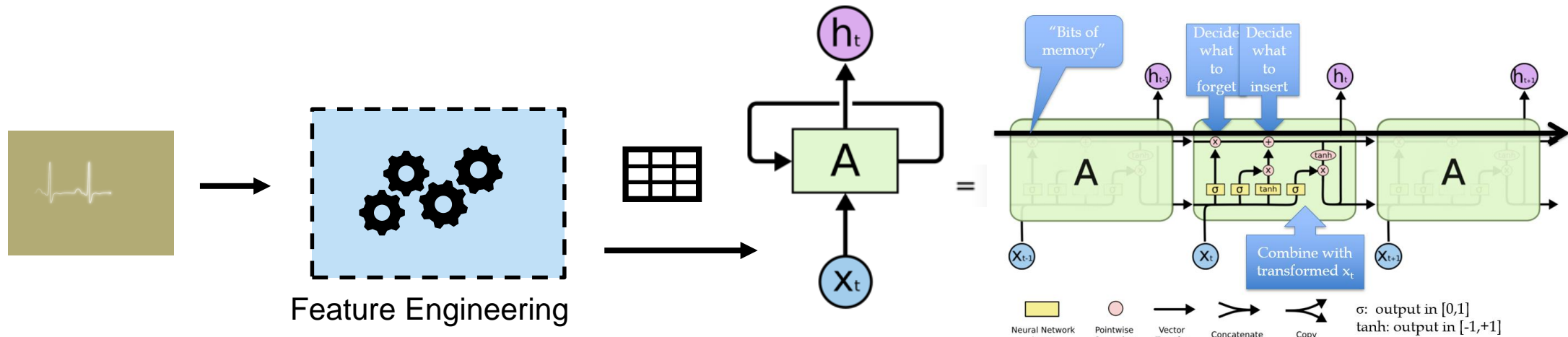

Deep Learning Workflow

CREATE AND ACCESS DATASETS

PREPROCESS AND TRANSFORM DATA

DEVELOP PREDICTIVE MODELS

ACCELERATE AND DEPLOY

Data sources

Simulation and augmentation

Data Labeling

Pre-Processing

Transformation

Feature extraction

Import Reference Models/ Design from scratch

Hardware-Accelerated Training

Analyze and tune hyperparameters

Desktop Apps

Enterprise Scale Systems

Embedded Devices and Hardware

Deep Learning Workflow Challenges – Signals and Time Series

Deep learning models only as good as training data

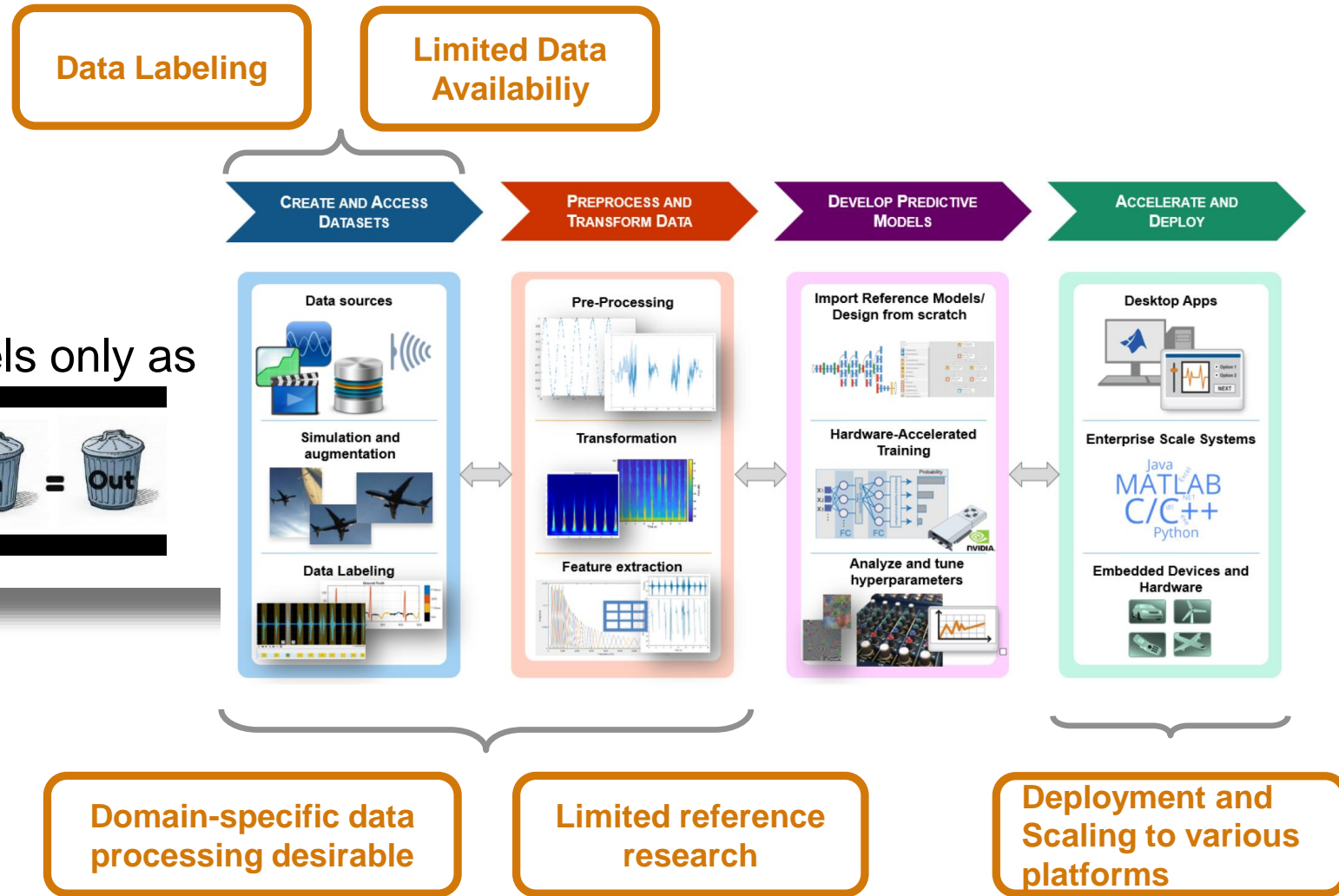
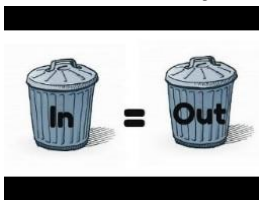

Agenda

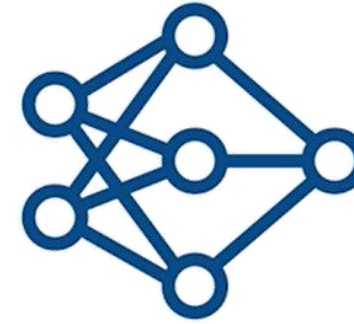

- Deep Learning – Basic ideas
- **Deep Learning Model Development for Signals, Time Series, and Text**
 - Data
 - Processing and transformation
 - Model design and optimization
 - Acceleration, prototyping, and deployment
- Conclusions

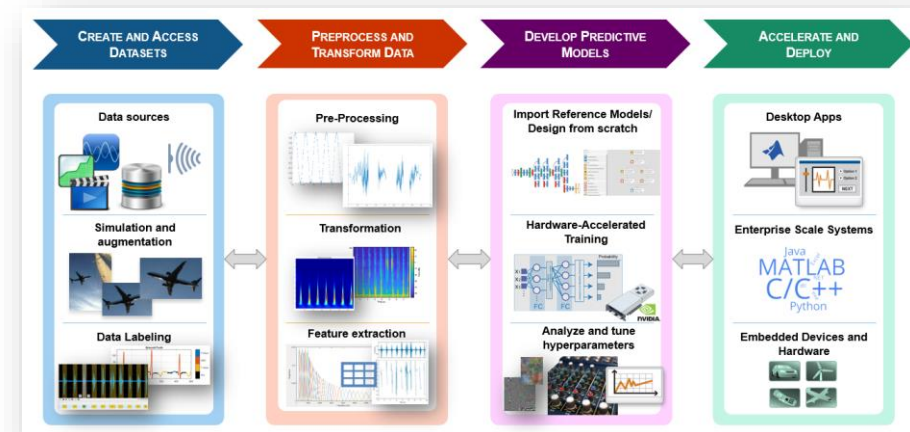

Agenda

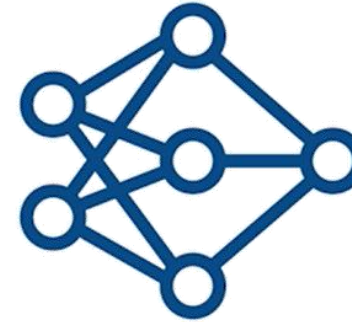

- Deep Learning – Basic ideas
- Deep Learning Model Development for Signals, Time Series, and Text
 - **Data**
 - Processing and transformation
 - Model design and optimization
 - Acceleration, prototyping, and deployment
- Conclusions

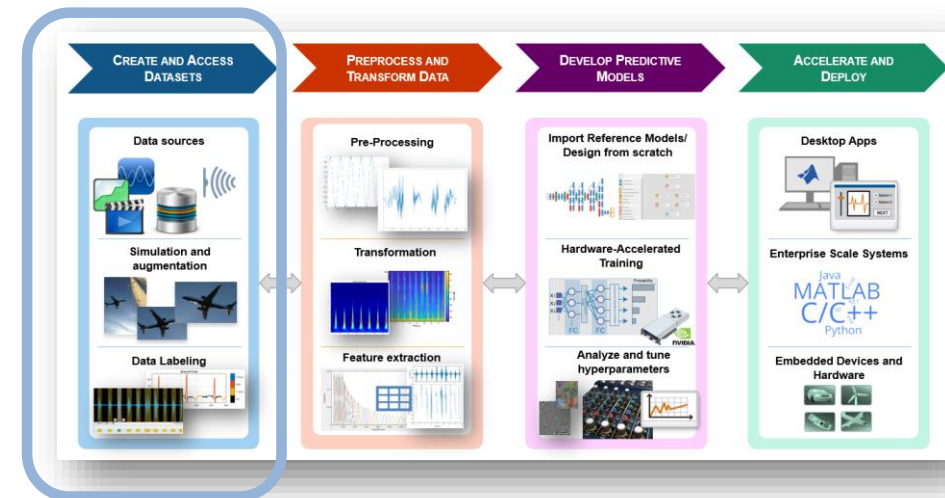

Current Investments – Models vs. Data

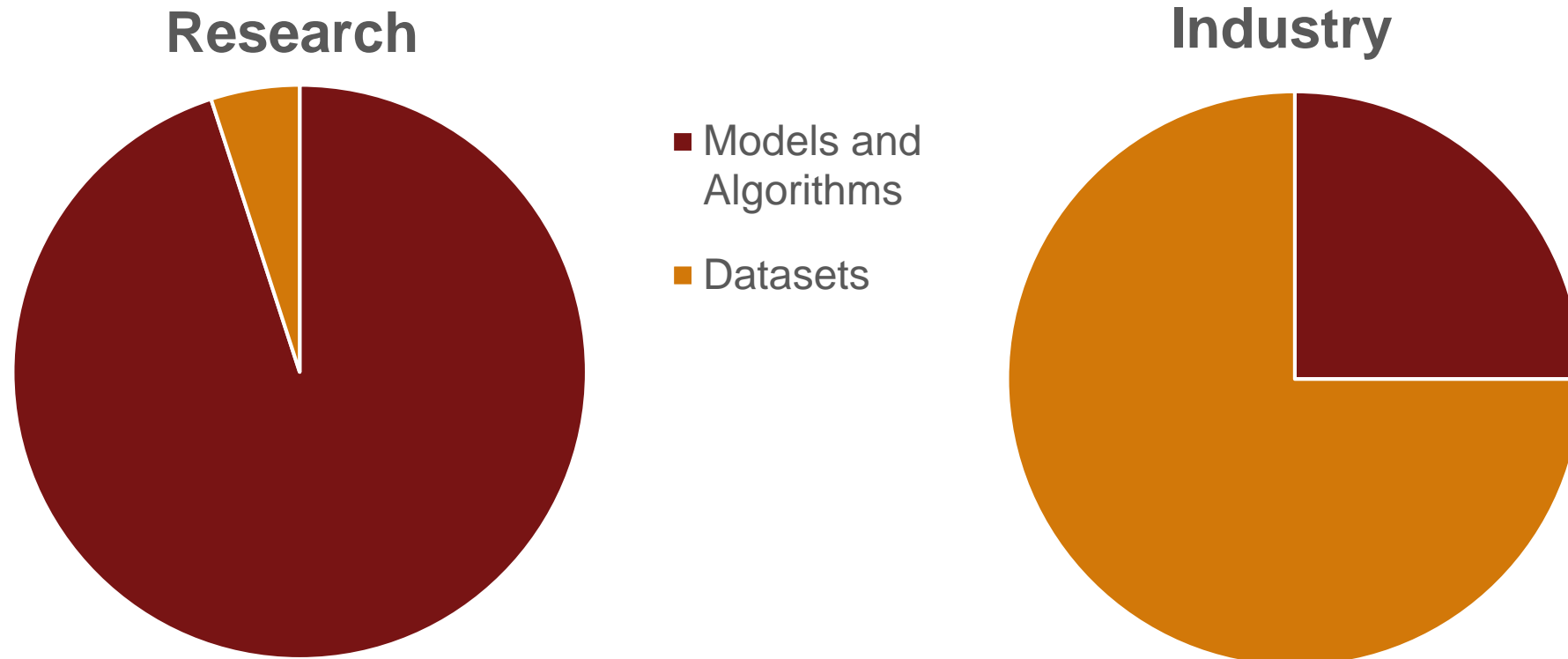

What does a large dataset look like?

How to navigate, index, read (and write)

audioDatastore

imageDatastore

fileDatastore

Custom Datastores

How to...

- Build a list of all data and labels?
- Review basic statistics about available data?
- Select data subsets without nested `for` loops, `dir`, `ls`, `what`, ... aplenty?
- Jointly read data and labels?
- Automatically distribute computations?

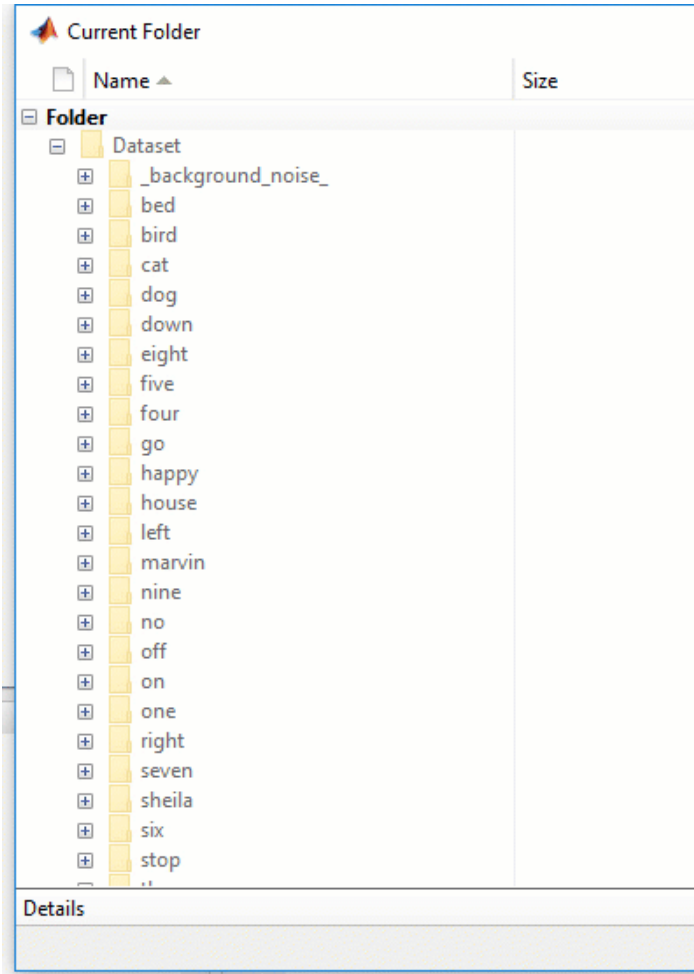

Label quality impacts model performance as much as the quality and quantity of the actual recordings

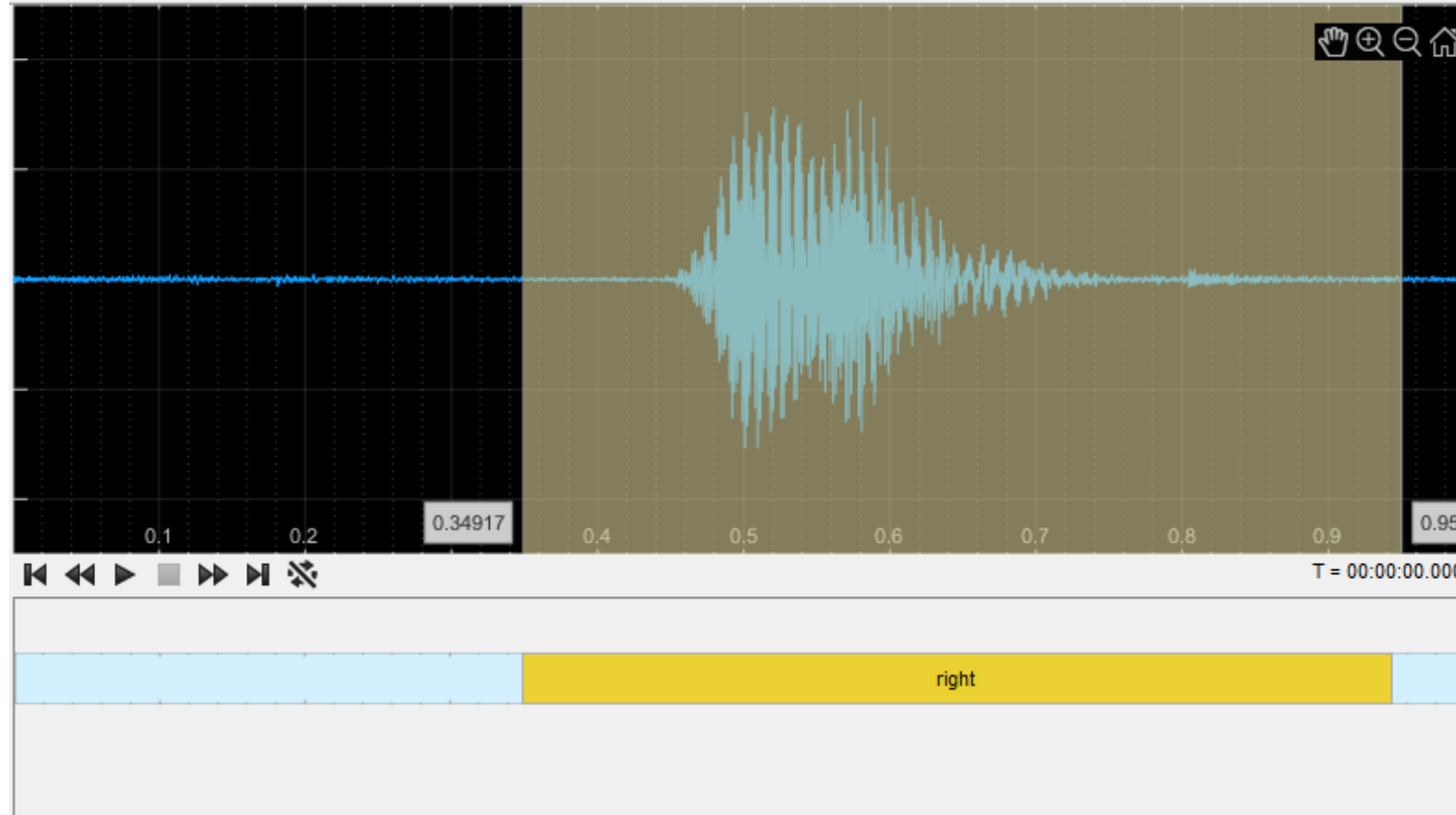

Use appropriate tools to help you label signals

```

patientID = 1;
signalVals = getSignal(QTData,patientID);
labelVals = getLabelValues(QTData,patientID,'WaveformLabels_Chan1');

displayWaveformLabels(signalVals(1,1:1000),labelVals.Value(1:1000))
    
```

Inspect the label values

- Programmatically...

- ... or via Apps

What if available data isn't enough?

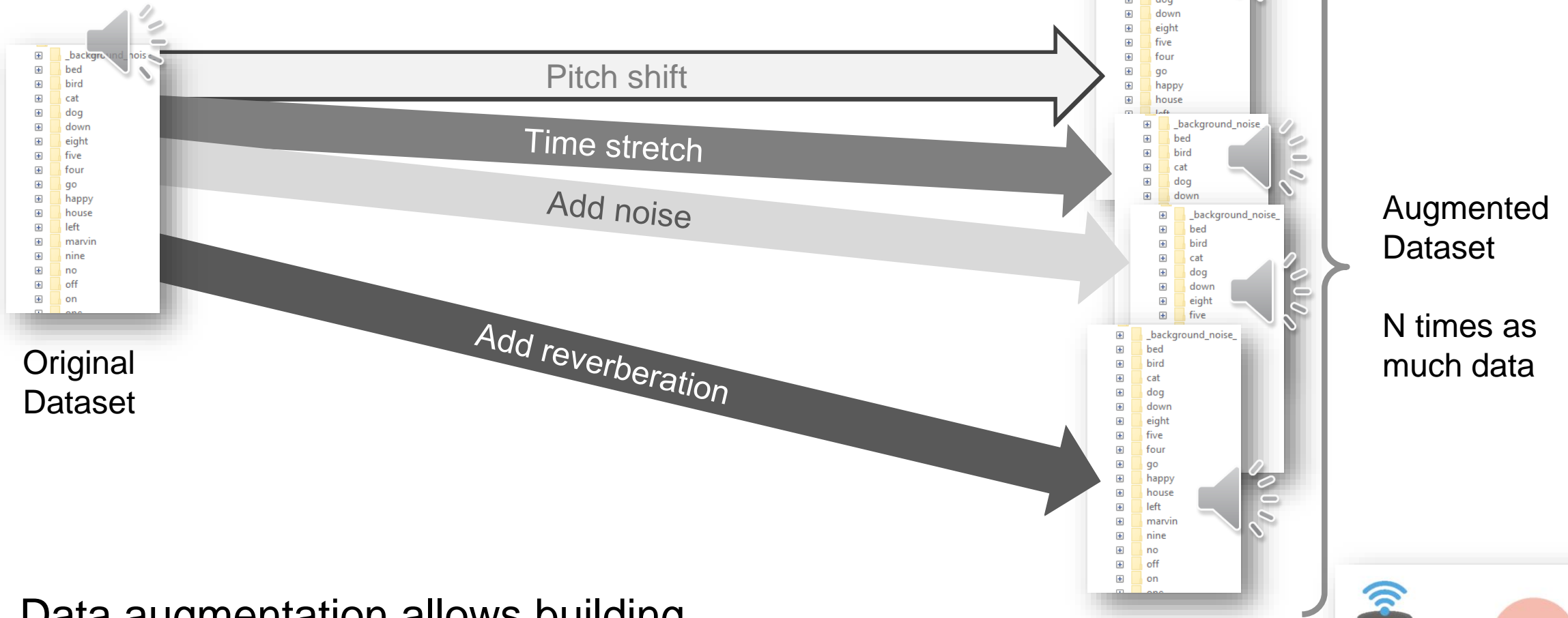

Data augmentation allows building more complex and more robust models

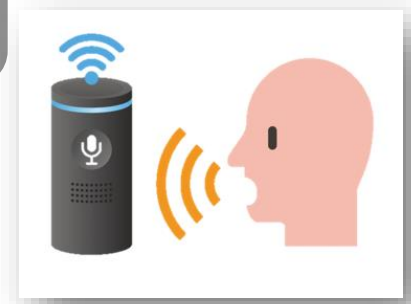

Simulation is key if recording and labelling real-world data is impractical or unreasonable – Communications Signals

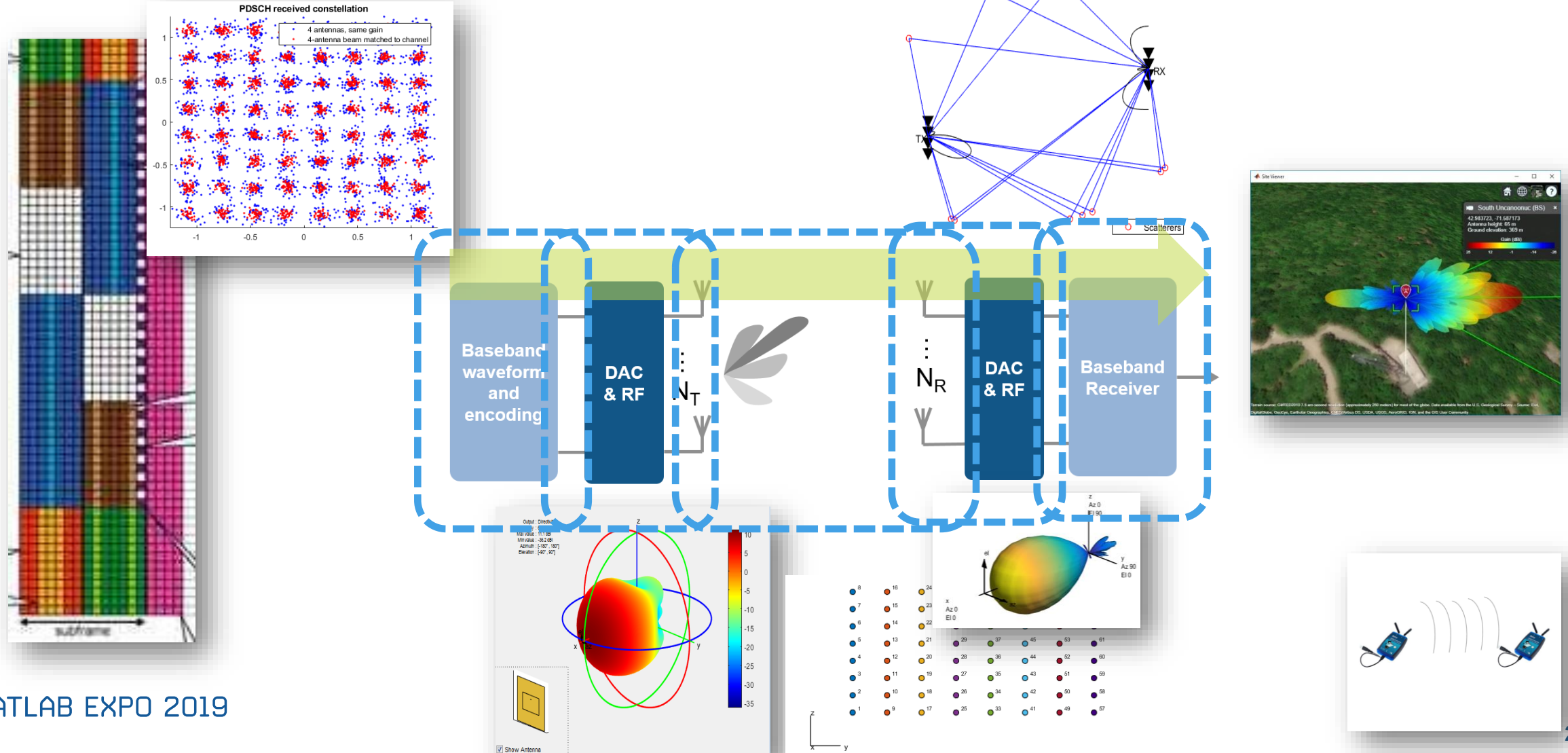

Simulation is key if recording and labelling real-world data is impractical or unreasonable – Radar Signals

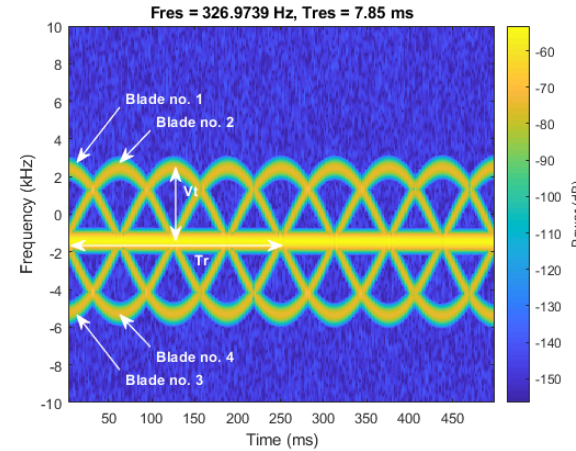
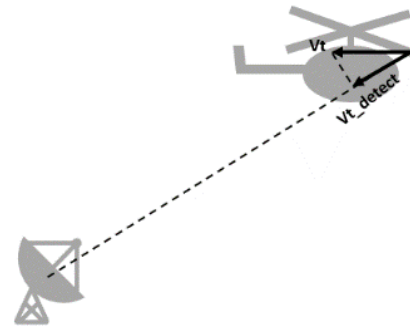

Radar Target Simulation

Micro-Doppler Analysis

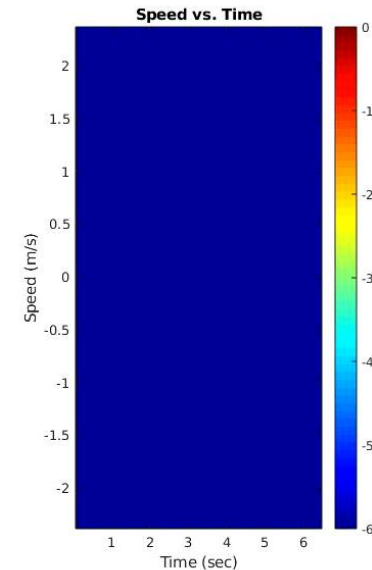
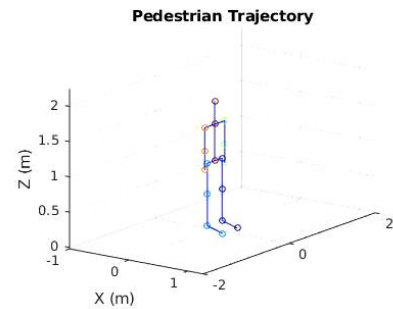

Agenda

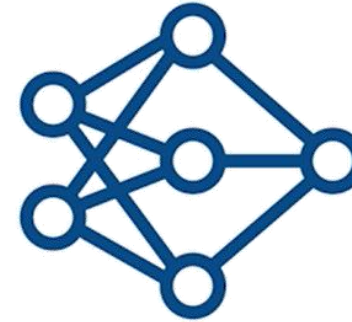

- Deep Learning – Basic ideas

- Deep Learning Model Development for Signals, Time Series, and Text
 - Data
 - **Processing and transformation**
 - Model design and optimization
 - Acceleration, prototyping, and deployment

- Conclusions

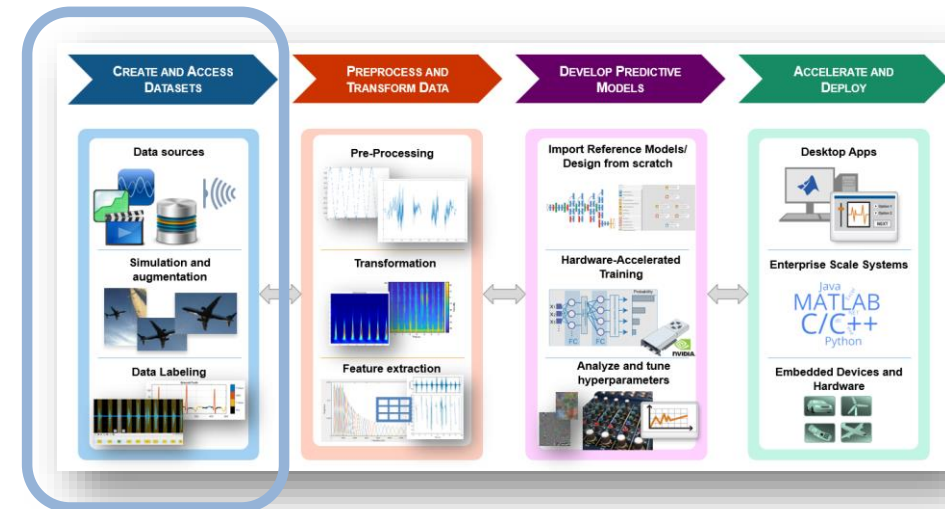

Common types of network architectures used in signal processing and text analytics applications

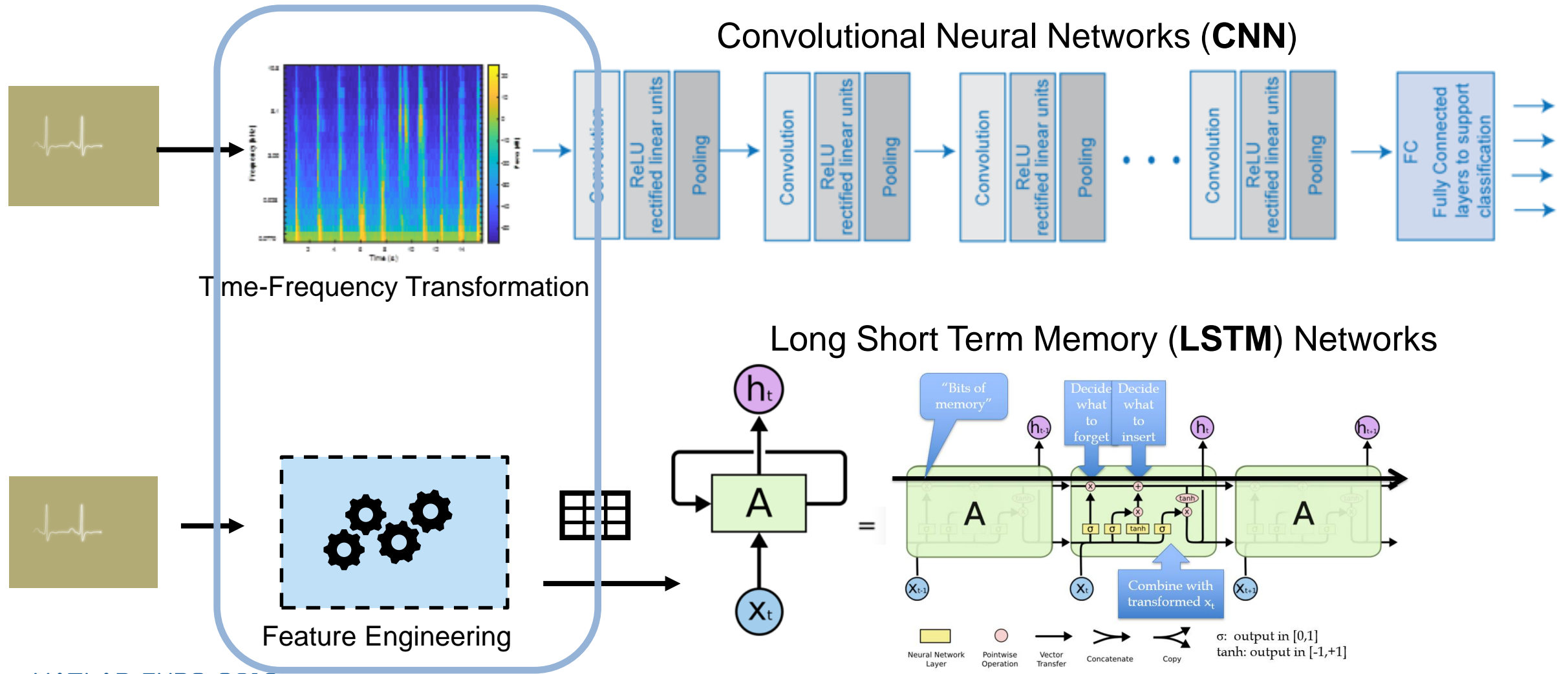

Time-Frequency Transformations

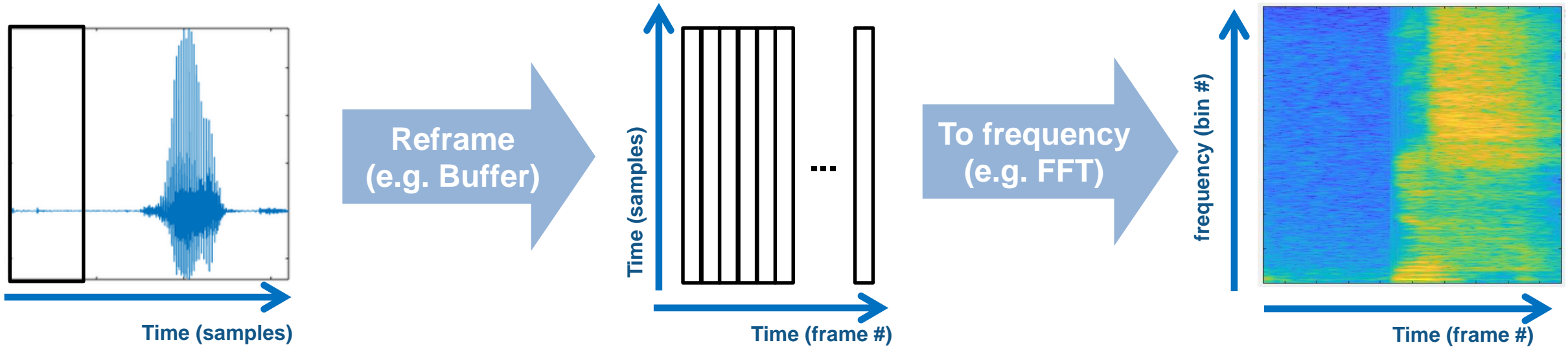

Easiest to understand and implement

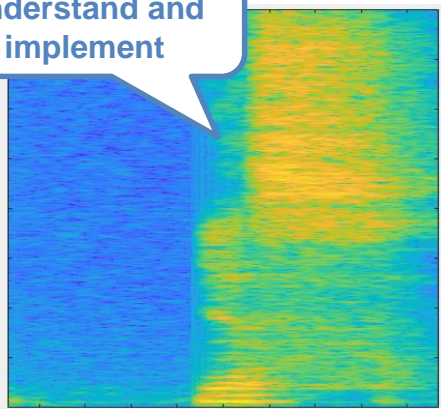

Basic spectrogram
MATLAB EXPO 2019

More compact for speech & audio applications

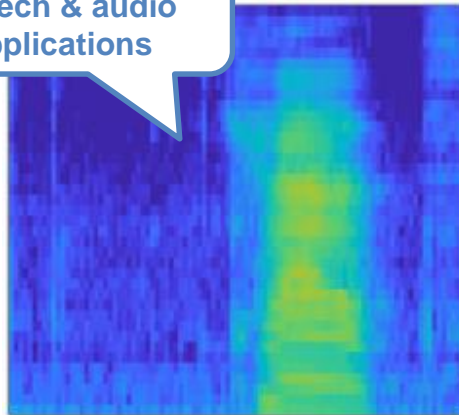

Perceptually-spaced (e.g. Mel, Bark) Spectrogram

Best resolution, for non-periodic signals

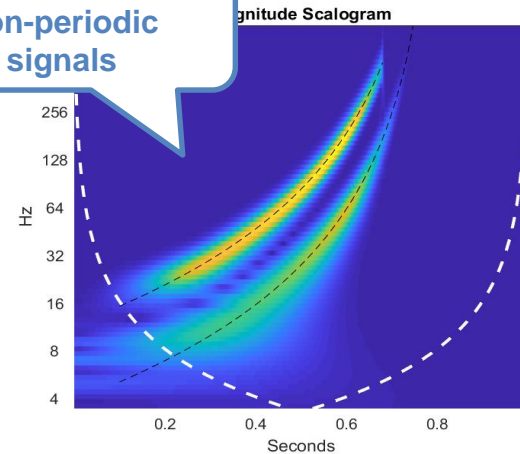

Wavelet scalogram

Better resolution at low frequencies

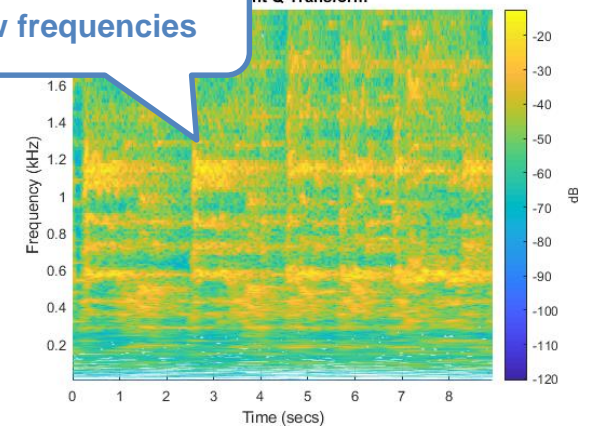

Constant Q transform

Extracting Features from Signals: Application-Agnostic Examples

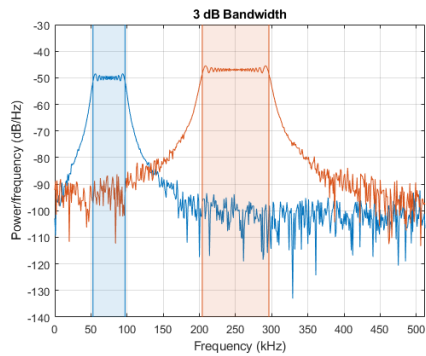

BW measurements

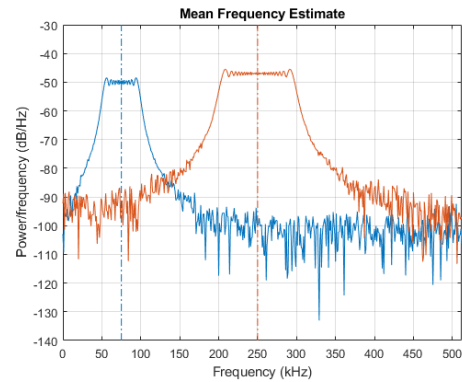

Spectral statistics

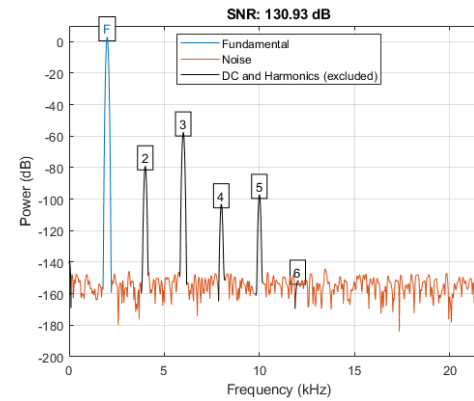

Harmonic analysis

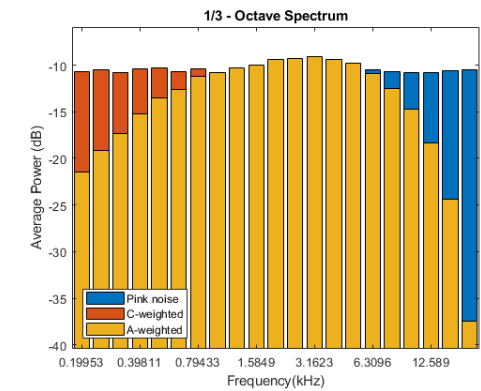

Octave spectrum

Frequency domain

Time domain

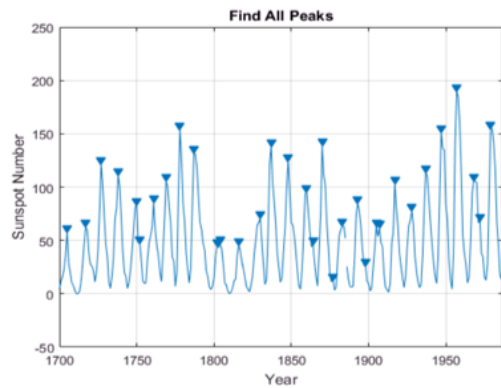

Find peaks

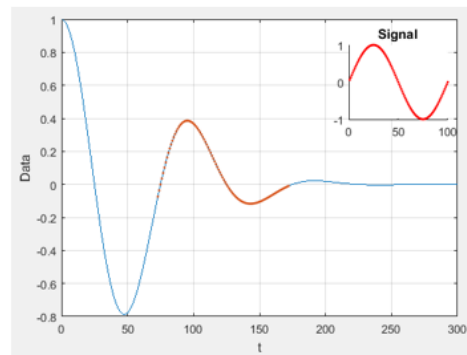

Find signal patterns

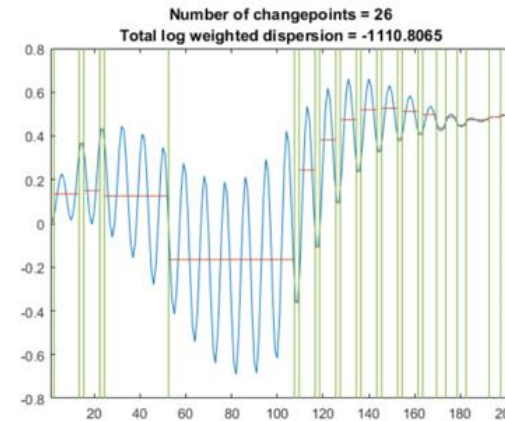

Detect change points

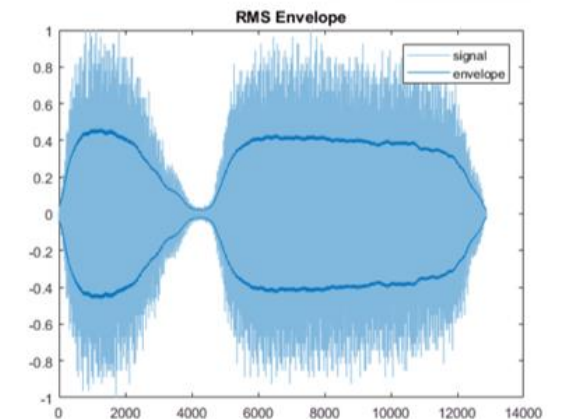

Find signal envelope

Domain-Specific Features and Transformations – Examples

Speech and Audio

- MFCC
- GTCC
- MDCT
- Pitch, harmonicity
- Spectral shape descriptors
- ...

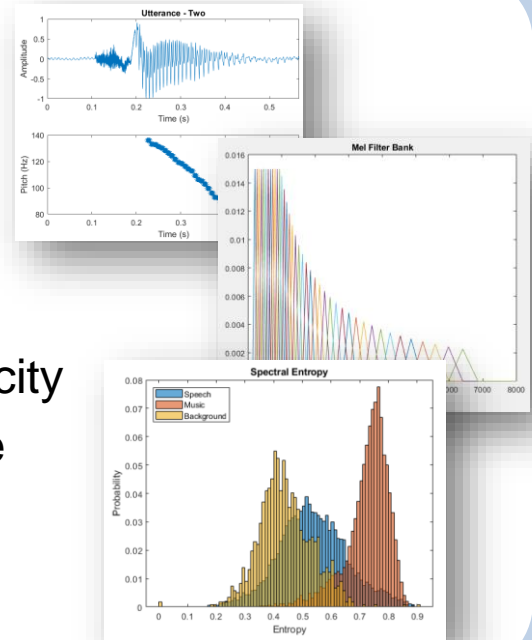

Navigation and Sensor Fusion

- Orientation
 - Height
 - Position
 - Multi-object tracking
 - ...
- from
- Acceleration, angular velocity
 - Magnetic field
 - GPS reading

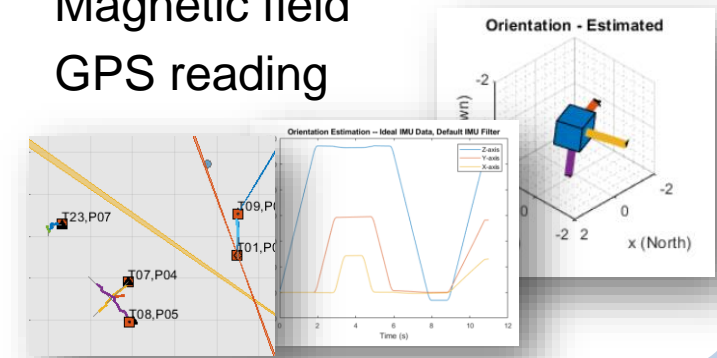

Text Analytics

- Train Word Embeddings
- Word2Vec
- Topic Modeling
- ...

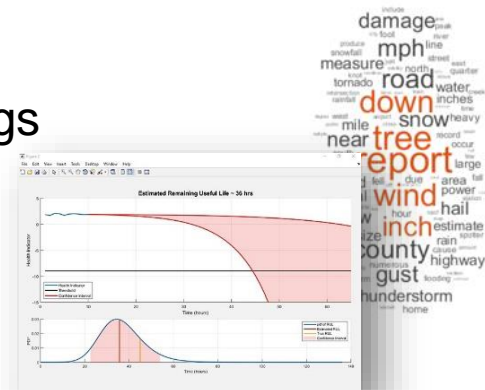

Radar

- Micro-Doppler analysis
- Range-Doppler processing
- Synthetic aperture imaging
- Spectral analysis
- Waveform ambiguity
- ...

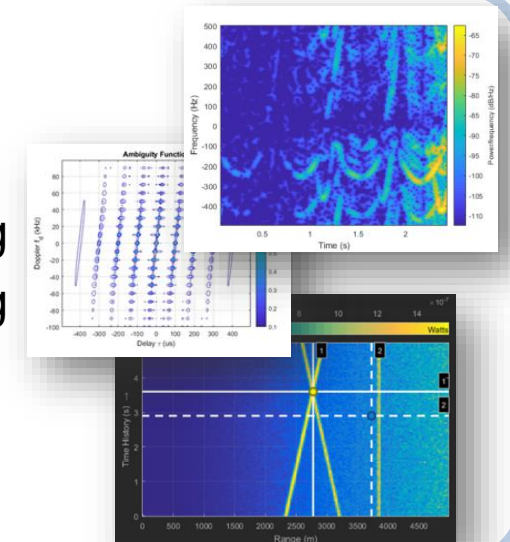

Automated Feature Extraction: Wavelet Scattering

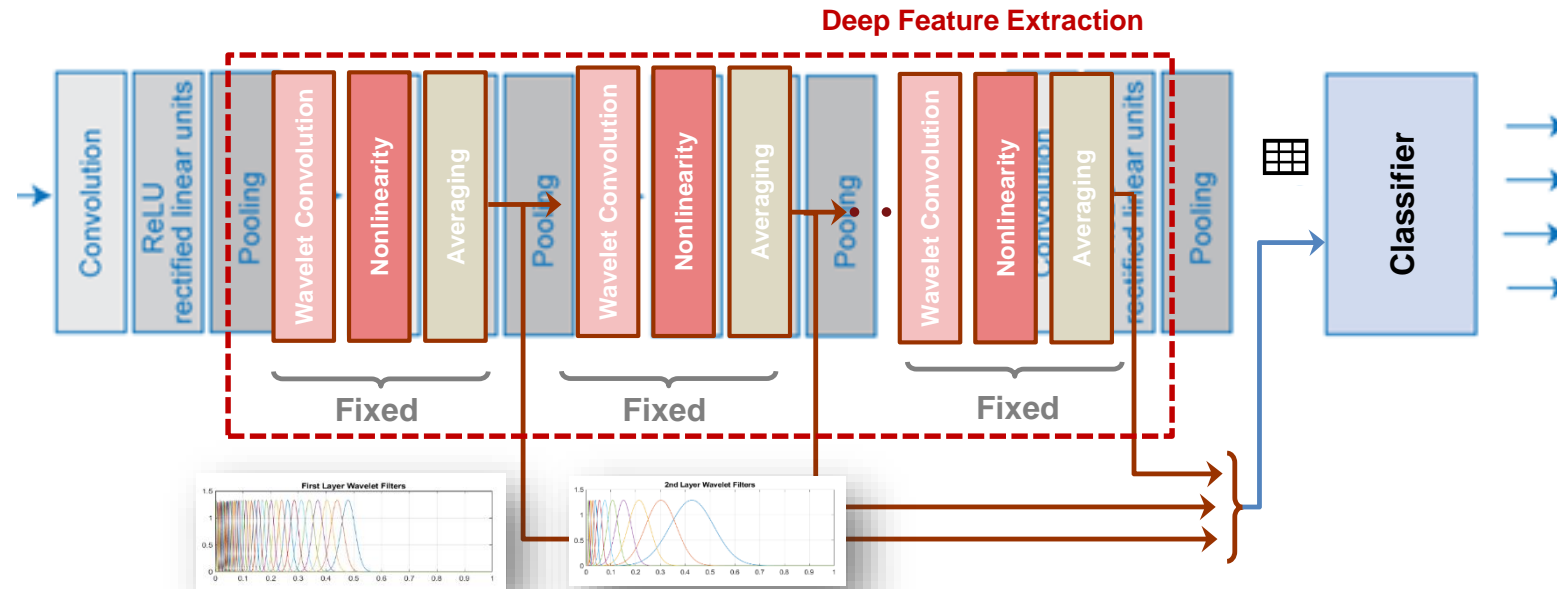

- Can relieve requirements on amount of data and model complexity
 - Featured in leader-boards a number of research competitions
- Framework for extracting features ^[1]

[1] Joan Bruna, and Stephane Mallat, P. 2013. Invariant Scattering Convolution Networks. [IEEE Transactions on Pattern Analysis and Machine Intelligence](#), Vol. 35, No. 8, pp. 1872-1886.



Agenda

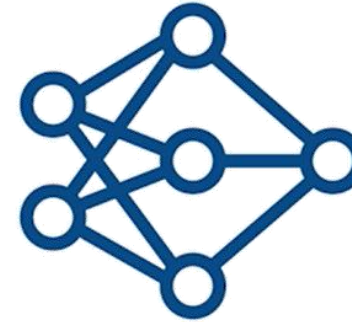

- Deep Learning – Basic ideas
- Deep Learning Model Development for Signals, Time Series, and Text
 - Data
 - Processing and transformation
 - **Model design and optimization**
 - Acceleration, prototyping, and deployment
- Conclusions

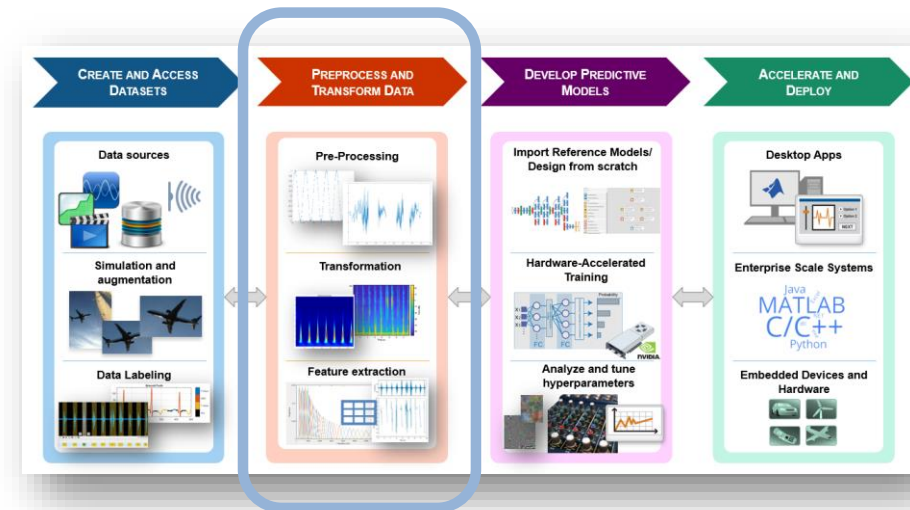

Developing Deep Learning Models

Design Network



Model Exchange

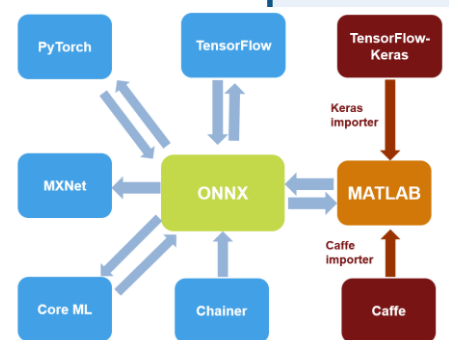

Design

Train

Accelerate Training



MATLAB as a container on NGC

Optimize

Pre-trained Networks

AlexNet PRETRAINED MODEL	VGG-16 PRETRAINED MODEL	ResNet-50 PRETRAINED MODEL	ONNX Converter MODEL CONVERTER
Caffe IMPORTER	GoogLeNet PRETRAINED MODEL	TensorFlow-Keras IMPORTER	Inception-v3 MODELS

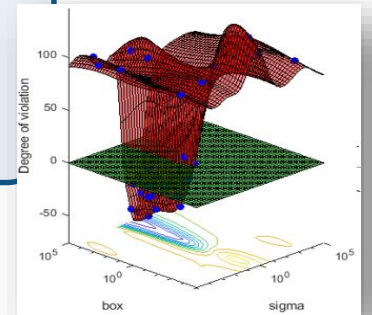

Bayesian Hyperparameter Optimization

Exchange Models With Deep Learning Frameworks

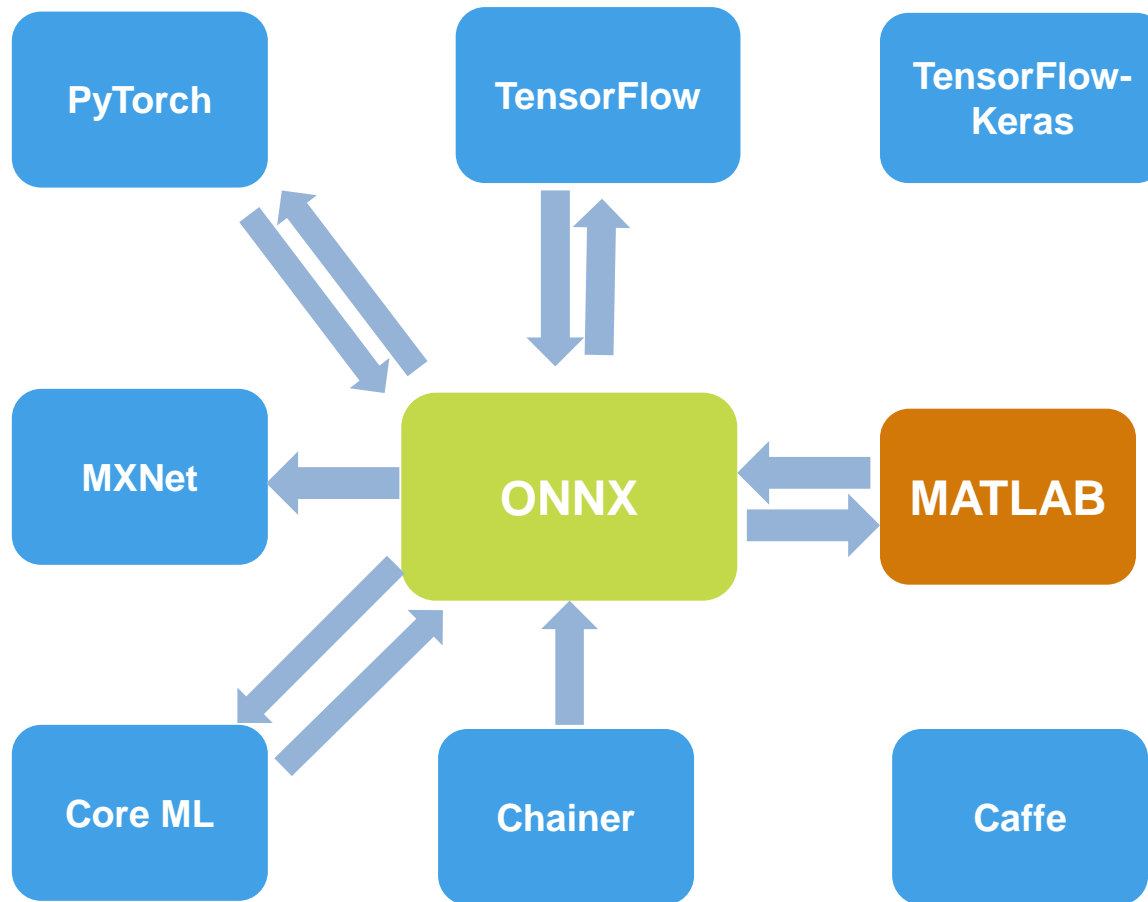

ONNX = Open Neural Network Exchange Format

Exchange Models With Deep Learning Frameworks

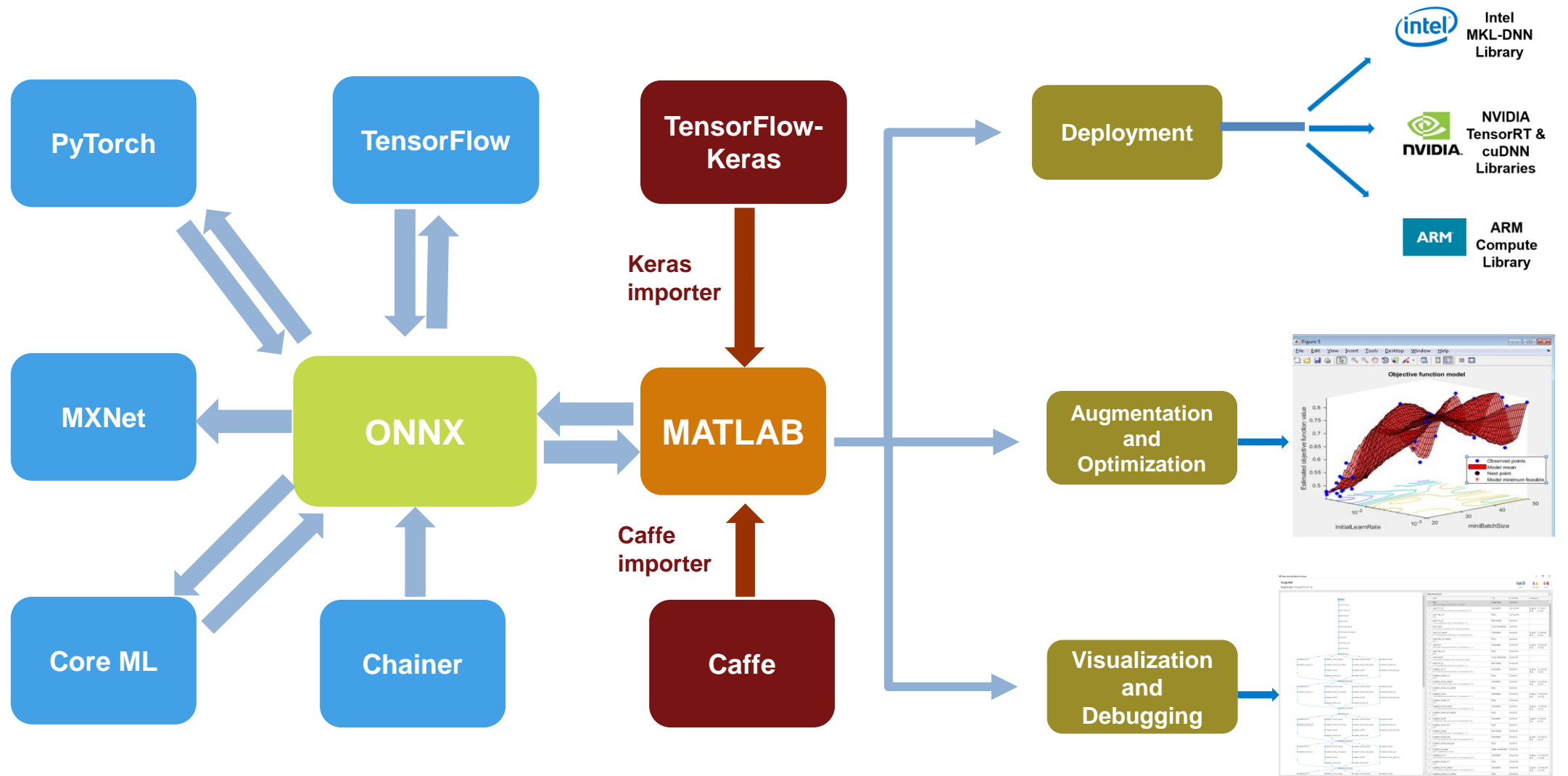

ONNX = Open Neural Network Exchange Format

Agenda

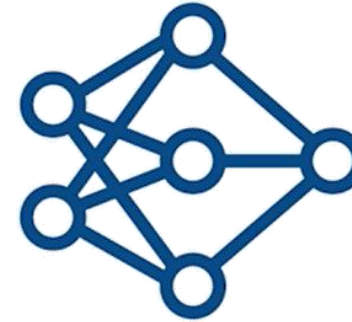

- Deep Learning – Basic ideas
- Deep Learning Model Development for Signals, Time Series, and Text
 - Data
 - Processing and transformation
 - Model design and optimization
 - **Acceleration, prototyping, and deployment**
- Conclusions

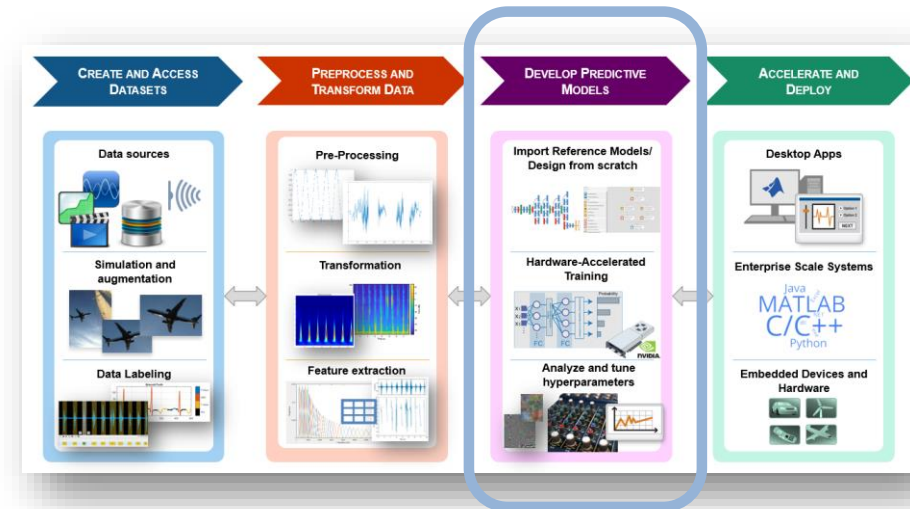

Deployment and Scaling for A.I.

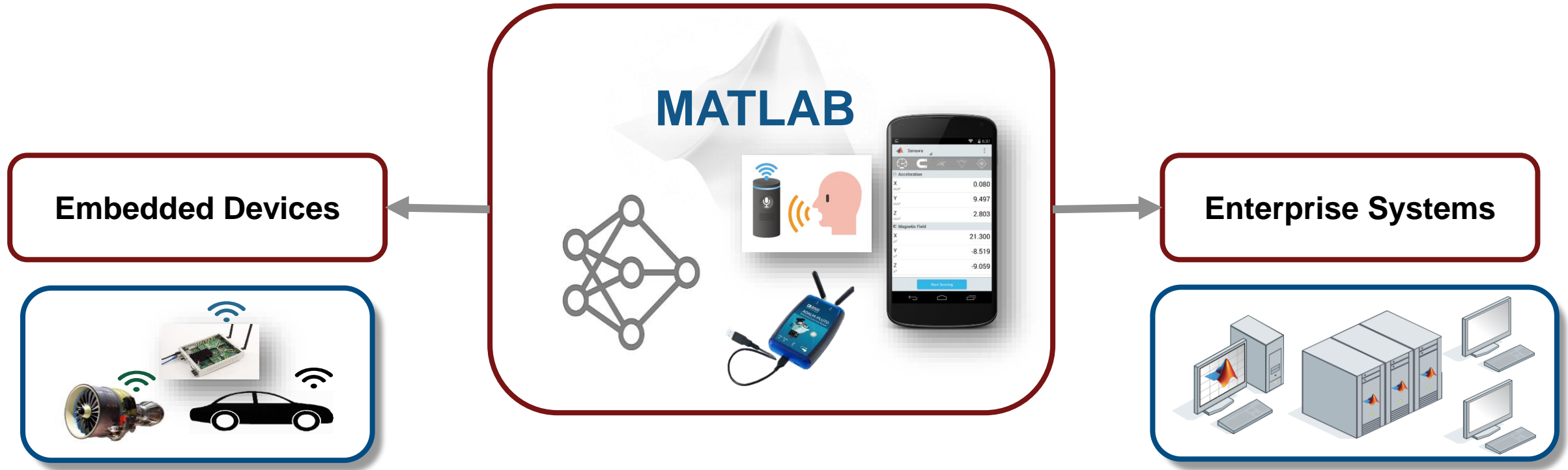

Deploying Deep Learning Models for Inference

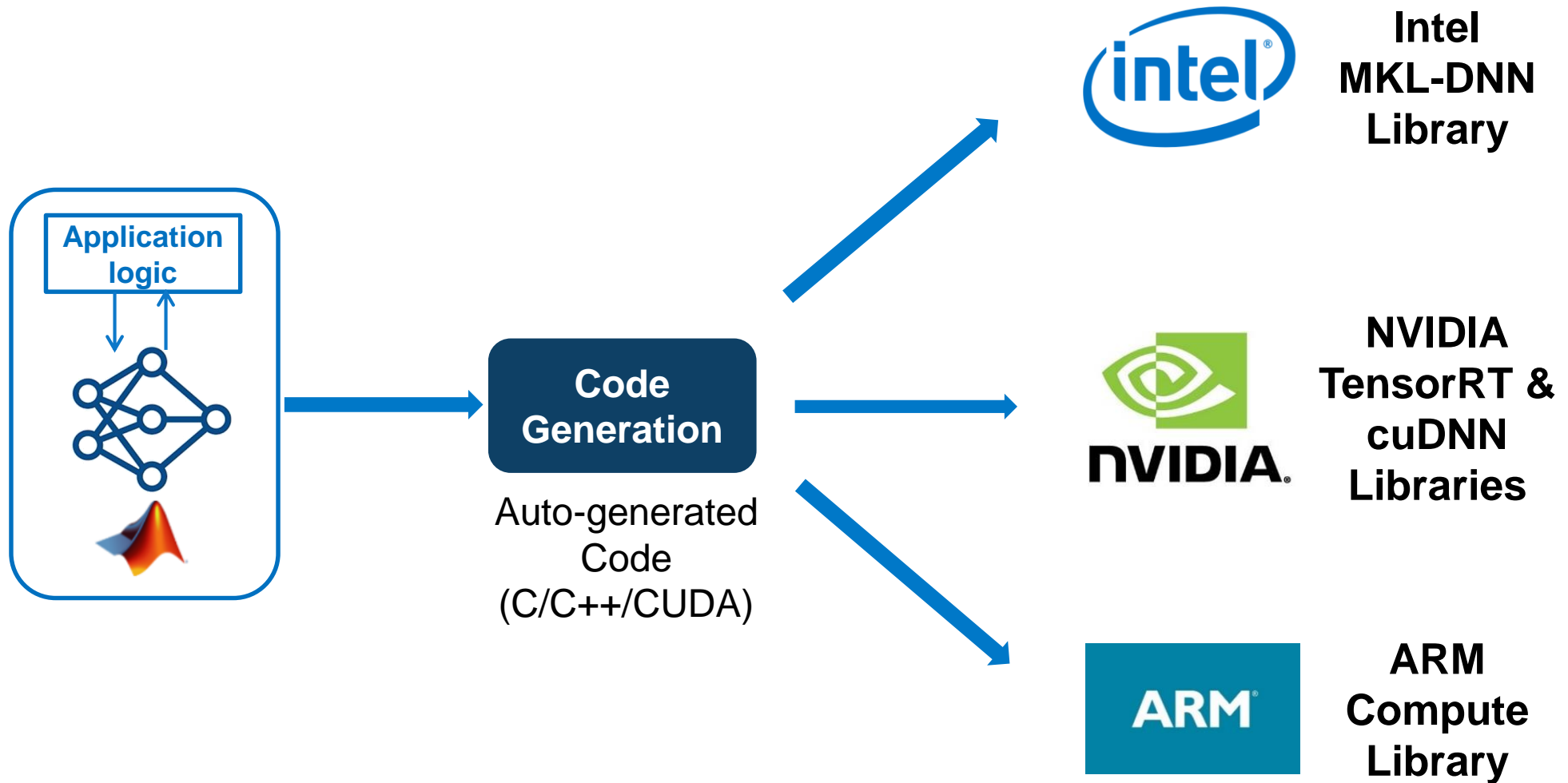

With GPU Coder, MATLAB is fast

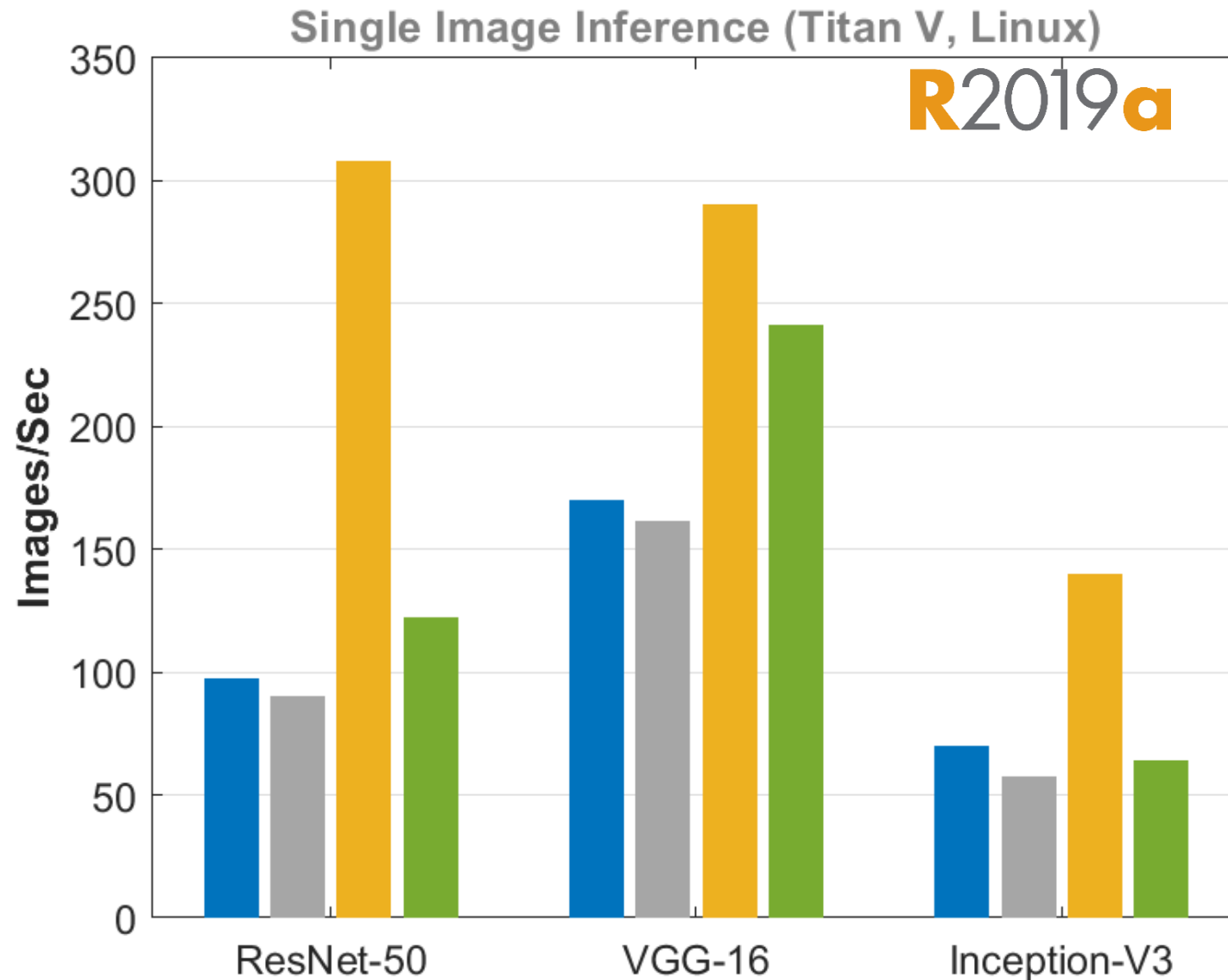

GPU Coder is faster than TensorFlow, MXNet and Pytorch

■ TensorFlow

■ MXNet

■ GPU Coder

■ PyTorch

Enterprise Deployment

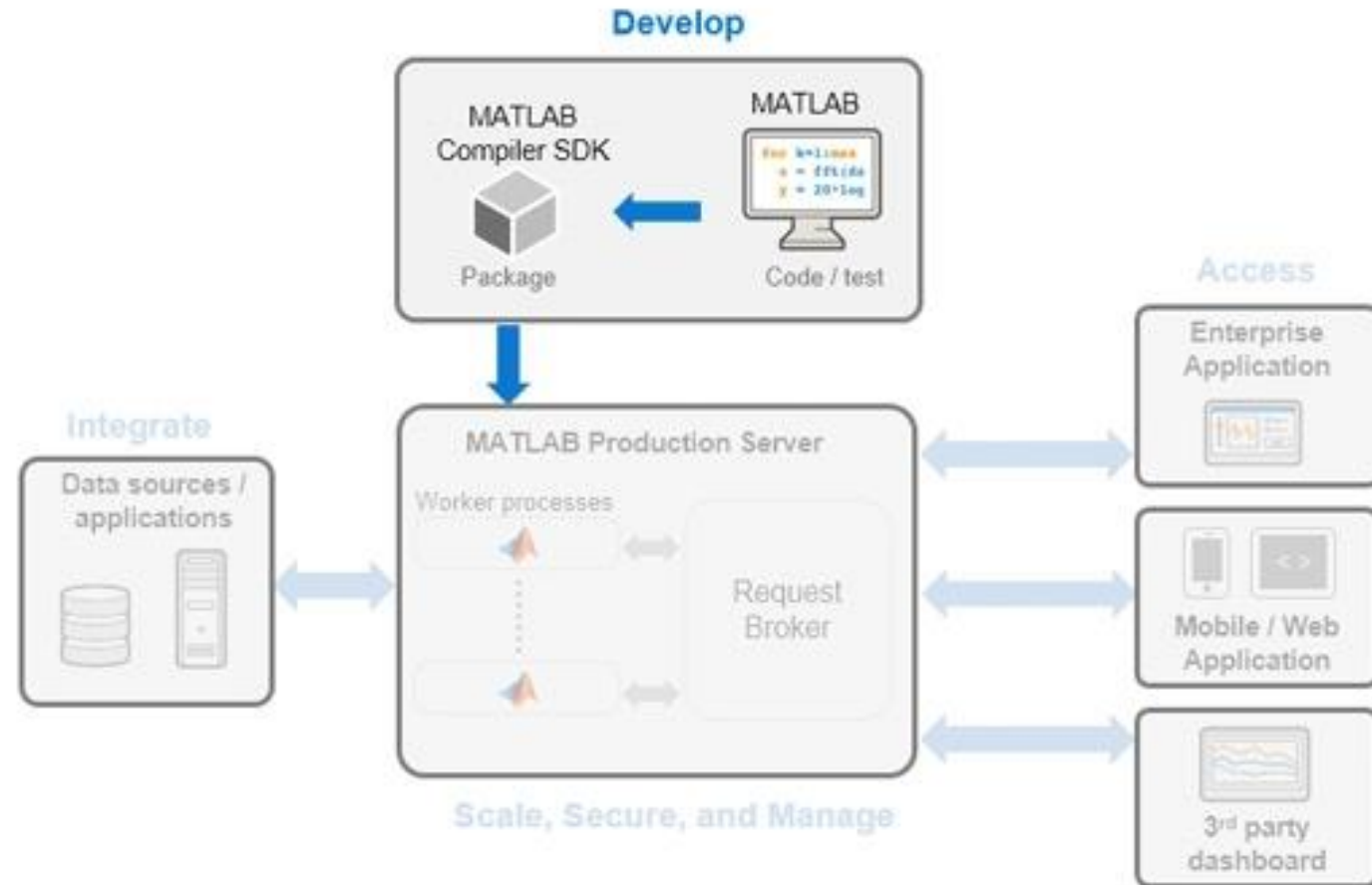

Deployment to the cloud with MATLAB Compiler and MATLAB Production Server

Agenda

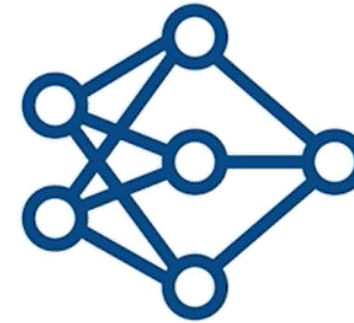

- Deep Learning – Basic ideas
- Deep Learning Model Development for Signals, Time Series, and Text
 - Data
 - Processing and transformation
 - Model design and optimization
 - Acceleration, prototyping, and deployment

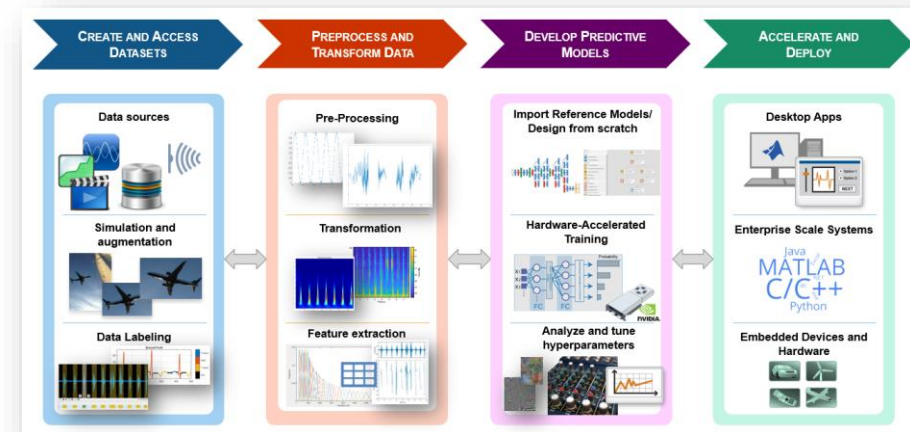

- **Conclusions**

Deep Learning Workflow Challenges – Signals and Time Series

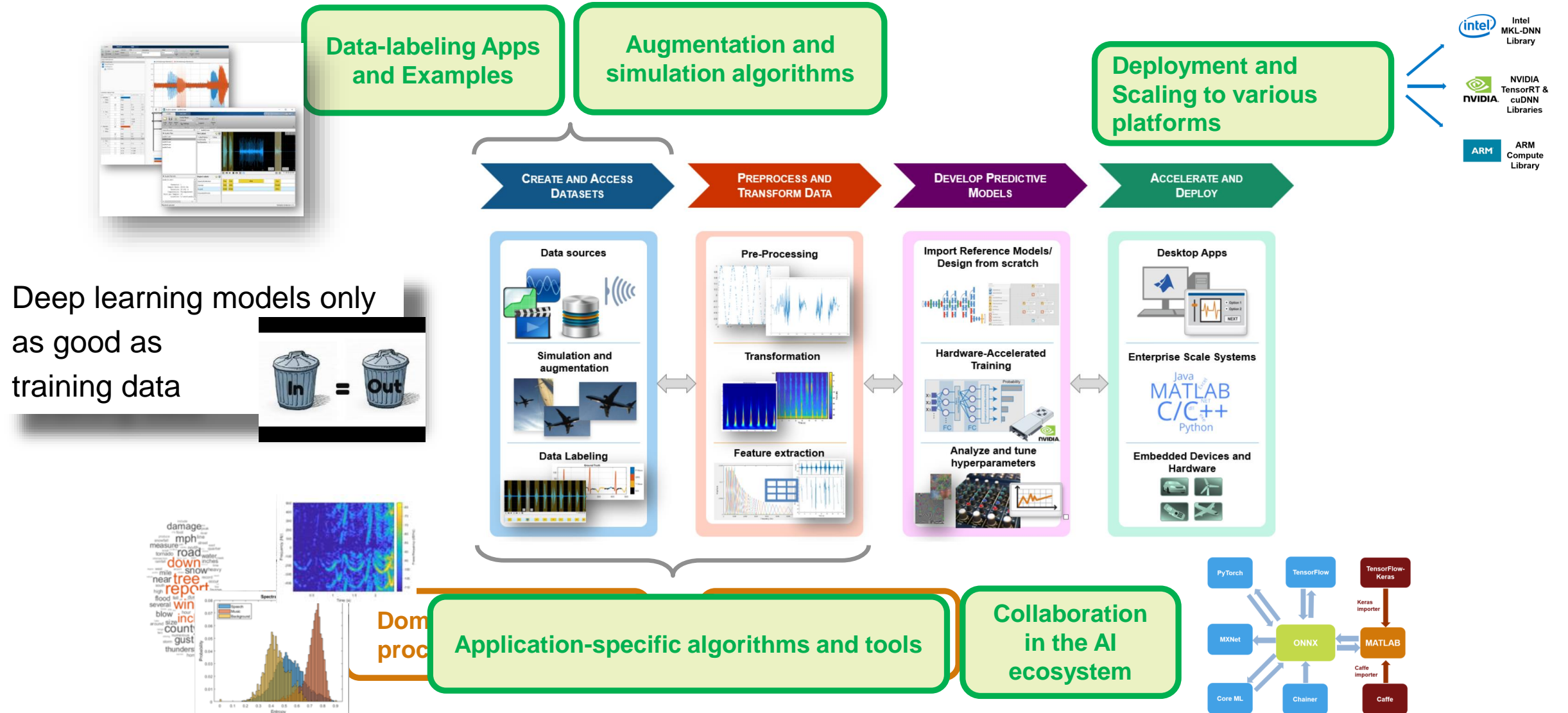

Domain-Specific Features and Transformations – Examples

Audio

[Speech Command Recognition](#)
[Voice Activity Detection in Noise](#)
[Denoise Speech](#)
[Classify Gender](#)

Time-Series and Text

[Classify Time Series Using Wavelet Analysis](#)
[Sequence-to-Sequence Classification](#)
[Classify Text Data Using LSTMs](#)
[Classify Text Data Using CNNs](#)

Signal

[Music Genre Classification](#)
[Human Activity Recognition](#)
[ECG Signal Classification](#)
[Waveform Segmentation](#)

Comms and Radar

[Radar Waveform Classification](#)
[Modulation Classification](#)

Call to Action - to be edited by the local team

- Visit the booth**
- Attend the talk on Deep Learning and Reinforcement Learning Workflows in A.I.**

Back up

Summary - Deep learning workflow in MATLAB

Deep Neural Network Design + Training

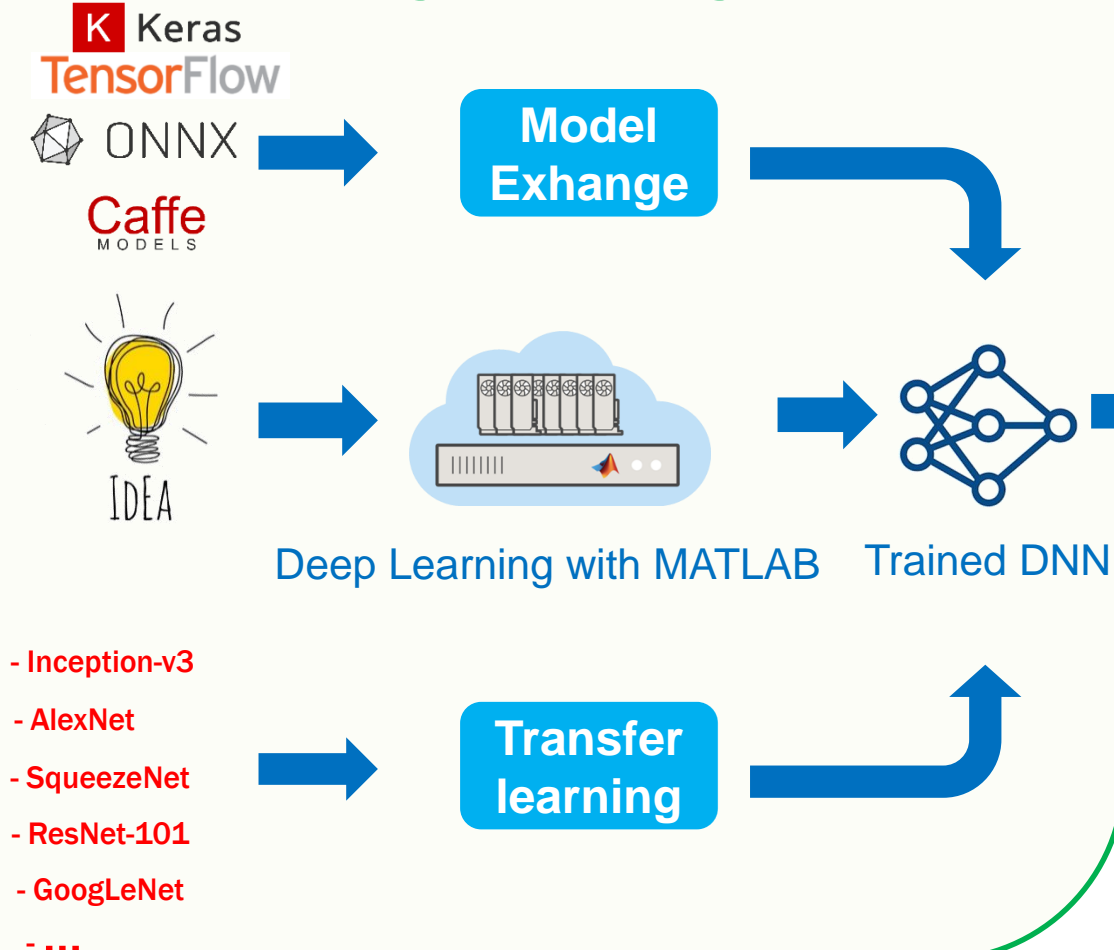

Application design

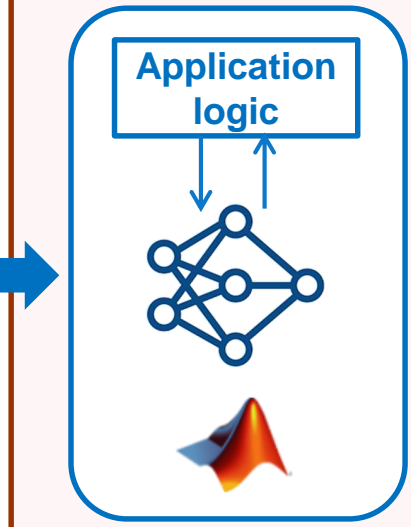

Standalone Deployment

Coders

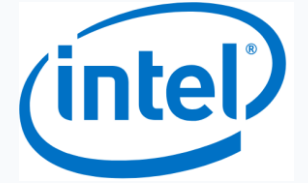

Intel
MKL-DNN
Library



NVIDIA.
NVIDIA TensorRT
cuDNN Libraries



ARM
NEON™
ARM Compute
Library